

TYPE EMR

KYOWA

EXHAUST GAS SCRUBBER

OPERATION MANUAL

THAI KYOWA KAKO CO.,LTD.

http:// www.kyowa.co.th

e-mail : tkk@kyowa.co.th

CONTENTS

1.SPECIFICATIONS.....	2
2.EXTERNAL VIEW.....	3
3.FUNCTION OF EACH SECTION.....	4
4.SAFETY CONTROL AND SAFETY OPERATION.....	5
5.TEST OPERATION.....	6
6.OPERATION	7
7.DAILY MAINTENANCE.....	9
8.MAINTENANCE AFTER LONG-TERM SUSPENSION OF OPERATION.....	11
9.DISASSEMBLY AND ASSEMBLY OF COMPONENTS FOR MAINTENANCE SYSTEM	11
10.TROUBLESHOOTING.....	13
11.GUARANTEE.....	14

WARNING

This system could be used only in a right purpose and right condition. If some abnormal state occurred, stop the operation of gas generating source. Next, inspect exhaust gas treatment system, and this system can be resumed after restoring all the breakdown section perfectly.

Warning

The Kyowa EMR-type exhaust gas scrubber sucks in the exhaust gas and, after scrubbing, discharges it into the air. The parts, which contact the exhaust gas are made of fiberglass reinforced plastic, which has excellent anti-corrosion properties.

Please, read this manual carefully before operating this unit so that it operates to its full performance and prevent malfunctions. This operation manual covers the general and basic precautions for the unit. For details on operating the exhaust fan, the circulation pump and other devices. Please, refer to each of the attached instruction manuals.

1. Specifications : (Refer to Specifications in part 2)

2. EXTERNAL VIEW

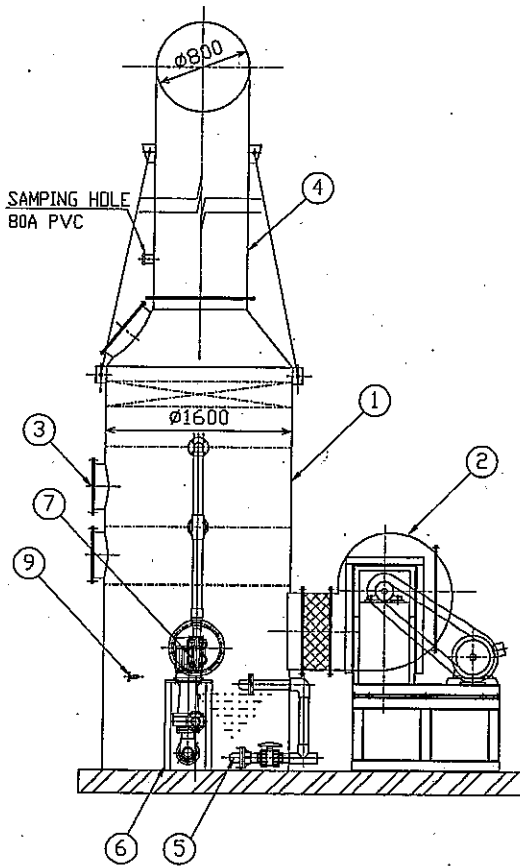
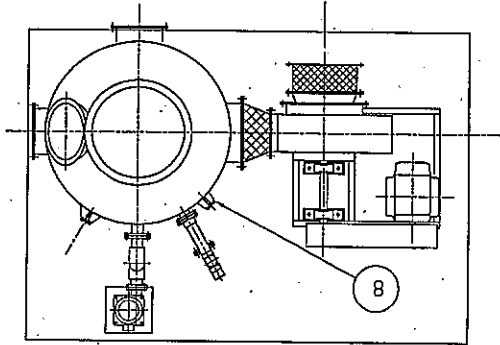

9	LC	FRP	2	20A JIS10K
8	WATER SUPPLY PORT	FRP	1	20A JIS10K
7	CIRCULATION PUMP	FRPP	1	
6	MOUNT OF PUMP	SS400	1	
5	DRAIN-OVER FLOW	PVC	1	80A JIS10K
4	STACK	FRP	1	$\phi 800 \times 5000H$
3	HANHOLE	FRP	4	$\phi 400 \times 3, \phi 500 \times 1$
2	EXHAUST FAN	FRP	1	
1	SCRUBBER	FRP	1	$\phi 1600 \times 3350H$

3. Function of each section.

The Function of each parts are following.

(1) Exhaust Fan

The function of fan is to transport the exhaust gas to scrubber.

(2) Circulation pump

The function of circulation pump is to suck circulation water form circulation tank and carry them to nozzle, and sprinkle on exhaust gas flow.

(3) Scrubber main body

Scrubber main body consists of spray nozzles, mist separator. Function of scrubber is to absorb pollutant form exhaust gases, which is based on mass transfer theory of chemical engineering.

1. Spray nozzle

To spray the absorbent water on the tower packing uniformly.

2. Mist separator.

To remove the droplets from exhaust gases, which is generated from the spraying inside the scrubber.

4. Safety control and safety operation

When test running or inspection is started, be careful of safety operation, especially in next item.

(1) This apparatus is made of PVC or FRP, so the hammer impacted on the PVC surface or other impacted could break the scrubber main body.

The range of temperature in which plastics can be used isn't so wide. If plastics are used beyond the limits of temperature. Plastic will be deformed or broken.

Permitted range of temperature: 0~40⁰ C

If flame get close to plastics apparatus, plastics burn and cause fire, so please be careful not to get close to plastics.

(2) However, this apparatus can remove the pollutant from exhaust gases by certain extent. A little pollutant still remain in there after treatment gas. because this apparatus can't absorb the pollutant perfectly.

Breathing the gas which out of from the scrubber. cause danger for your health.

So please, be careful! Don't breathe the gas directly. keep enough distance between this scrubber and any other outer air intake port, so as not to contaminate indoor environment.

(3) During equipment is inspected. Please, make sure that power supply is turned off, so as not to have a serious accident.

(4) When you are under maintenance operation. Please, select the suitable tool in order to avoid suffering.

(5) If some operation in a high position is required, arrange enough scaffolding and take care of your safety.

(6) Before the operation concerning with electricity wiring, terminate electricity securely.

(7) When you treat absorbent (water) in this system. You must wear appropriate protection devices such as mask, goggles, gloves etc, because the water was mixed with some chemical substances. Which can suffer injury to your physical condition. If you touched circulation water. There may be some possibility of your damage. Please, have a medical treatment appropriately.

(8) Before operation in the scrubber, make an enough ventilate and wash out inside scrubber. So as not remain any poisonous gas in the scrubber.

When you getting in the scrubber. Please, wear the safety guard such as goggles, gloves, mask or waterproof coat. When you are under operation. Please, shuts off the generating source of pollutant including the exhaust fan and pump also.

(9) When the absorbent water being grained out. Specify and investigate what the poisonous substance in, and drain out after legal treatment appropriately.

(10) When this apparatus become disuse and scrap. Please, contact to expert firm. If you throw away this apparatus as general article, unexpected damage may be caused.

5. Test operation

Perform the test operation in accordance with the following procedure.

(1) Circulation pump

1) After completing installation, piping and wiring of the circulation pump. Clean the inside of circulation tank and pour it with the water up to the level where water overflows.

2) Turn the switch on and off to make sure the circulation pump rotates in the direction marked on the main body of the pump and then switches on the unit for operation.

3) After rotation of the circulation pump becomes correct. Measure the current flowing through the motor and must sure that current is lower than the specified value (the rated value of current specified on the nameplate of the circulation pump). Then keep the condition of valve in circulation pump.

(2) Exhaust fan

1) After completing installation, duct work and wiring of the exhaust fan, inspect and clean the inside of the duct. If any foreign mater is sucked during operation. The exhaust fan might be broken.

2) Before switching the motor on, turn the fan by hand to make that it rotates smoothly.

3) Set the volume damper at the half.

4) Turn the switch on and off to make sure the exhaust fan rotates in the direction marked on the main body of the fan. If its direction is incorrect. Change wiring of the motor.

5) After rotation of the exhaust fan becomes correct. Switch on the unit for operation.

6) Set the volume damper to adjust air flow rate to rated value.

7) Measure the current of the motor and make sure that current is lower than the specified value (the rated value of current specified on the nameplate of the motor.)

If the current exceeds the rated value, reduce it lower than the rated value by reducing the air flow rate through the damper.

(3) Scrubbing Tower

1) Observe the inspection port of spray nozzle, check that the packing are evenly distributed and that spray from the spray nozzles is uniform.

2) Check the outside for cracking or leaking.

6.Operation

After improvement through a test operation that all of devices are corrected. Operate the unit in accordance with the following procedure.

(1) Start

- Must sure that the circulation tank is filled with circulation water up to specified(overflow) level.
- Turn the circulation pump on before opening the delivery valve.
- After sure that the circulation pump is working correctly. Turn the exhaust fan on.
- Start supplying water.
- Measure the air flow rate in the initial operation and set it to the specified value.

(2) Stop

- Stop the water supply.
- Switch off the exhaust fan.
- Switch off the circulation pump.

(3) When the electric power is cut off. Turn the exhaust fan and circulation pump off. After the power supply is recovered. Start the operation from the beginning.

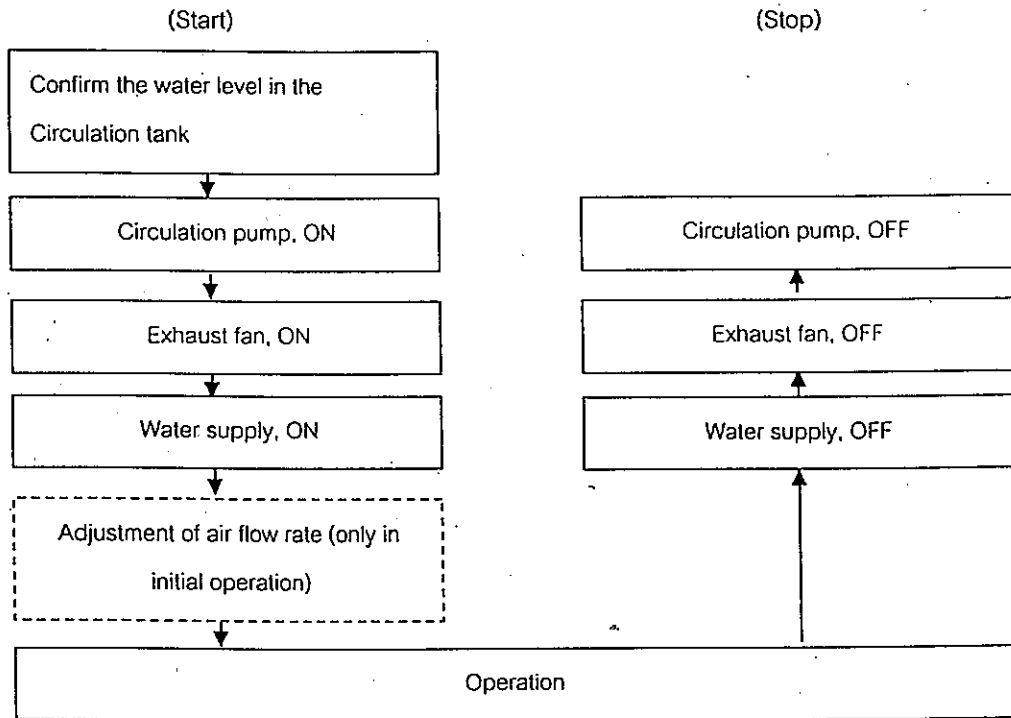

7. Daily maintenance

(1) Exhaust fan

1) V-BELT

The V-Belt might be stretched and slipped, especially at the initial stage of operation. If occurred, adjust the tension of the V-Belt by sliding the slide base of the motor. Replace the V-Belt with a new one according to the damage, which depends greatly upon r.p.m., operation term, condition of installation, etc.

2) Bearing

Lubricate the bearing using high-grade grease with a lithium soap base every 2 to 6 months depending upon r.p.m., operation hours, bearing temperature, etc. If unusual noise or vibration is produced by damage, replace a new one.

(Grease to used)

Maker	Brand name
Shell	ALBANIA Nos.2 and 3
Cosmo	REMAX Nos.2 and 3
Mobil	MOBILUX no.2

3) Runner

Depending upon the kind of gas sucked in, dust might adhere to the runner or the runner might be deformed by heat, and as the result, vibration occurs due to an unbalanced runner. Because such vibration might cause a sudden breakage of the bearing or the runner. Clean or replace the runner when vibration becomes intense.

4) Others

For details, refer to the attached " KYOWA Anticorrosive Blower Instruction Manual RFT Type"

(2) Circulation Pump

Circulation pumps which are used in this system, are maintenance –free vertical centrifugal pump with no sliding parts. So there no need for lubrication and replacement of parts. For vibration, noise or insufficient water lifting refer to the attached "Operation and Maintenance pump Pan wold ".

(3) Scrubber Tower

1) Spray nozzles

If spraying isn't uniform when viewed through the inspection port for spray nozzle. The nozzles might be blocked. Remove and clean the nozzles.

2)Demister

The demister might similarly be blocked with dirt. So if the demister is clogged. Mist can disperse from the stack or the exhaust gas suction capacity, might be reduced. In this case, remove and clean or replace a new one.

8.Maintenance after long-term suspension of operation

(1) When operation of the unit is suspended for a long-term, operate the exhaust fan and the circulation pump once a month for more than an hour under normal operating conditions.

(2) When operation is suspended for a long-term in winter. When freezing might occur, completely drain circulation water. Also drain the pump piping at the same time.

(3) Before operating the unit after a long-term suspension of operation, perform a test operation in accordance with the procedure in "3. Test operation".

9. Disassembly and assembly of components for maintenance

If necessary, remove or replace the components of this unit in accordance with the following procedure after making sure that the exhaust fan and the circulation pump aren't operating and providing a safe foothold.

(1) Exhaust Fan

Refer to the attached "KYOWA Anticorrosive Blower Instruction Manual RFT".

(2) Circulation Pump

Refer to the attached "Operation and Maintenance Pump Panel".

(3) Scrubbing Tower (refer to "2. External View")

1) Cleaning Body

- Unfasten the bolts of inspection port and take off the cover plate of inspection port.
- Assemble by the reverse procedure as that for disassembly. Replace gaskets with new ones.

2) Replace of spray nozzles

- Unfasten the bolts of inspection port for spray nozzle and open the inspection port. (open plural port, if necessary)
- Put the spray nozzle out of scrubber main body through the inspection port.
- Spray nozzle can be taken off after removing the packing, in alternative method.
- Assemble the unit by the opposite procedure as that for disassembly.

Replace gaskets with new ones.

3) Replace of the demister

- Unfasten the bolts of inspection port for demister and take off the cover plate.
- Take off the cartridge and demister from scrubber main body.
- Assemble the unit by opposite procedure as that for disassembly

Replace gaskets with new ones.

10. Troubleshooting.

(Problem)	(Cause)	(Solution)
Gas isn't sucked in or the suction power is weak.	Failure of the exhaust fan.	Refer to (trouble-shooting for blower) in the attached(KYOWA Anticorrosive Blower Instruction
	The damper is closed.	Open the damper.
	The duct is clogged.	Check and clean the inside of the dust.
	Demister are clogged.	Clean or replace demister. (Replace circulation water)
Water doesn't come out of spray nozzles or spraying isn't uniform.	Circulation pump failure.	Refer to (Trouble-shooting for pump) in the attached (Operation and Maintenance pump Pan wold).
	Spray nozzles are clogged.	Clean or replace spray nozzles.(Replace circulation water)
	The water level in the circulation tank drops.	Supply water.(Confirm function of water source, ball tap and drain valve.
Mist scatters from the stack.	The demister is clogged.	Clean or replace the demister.

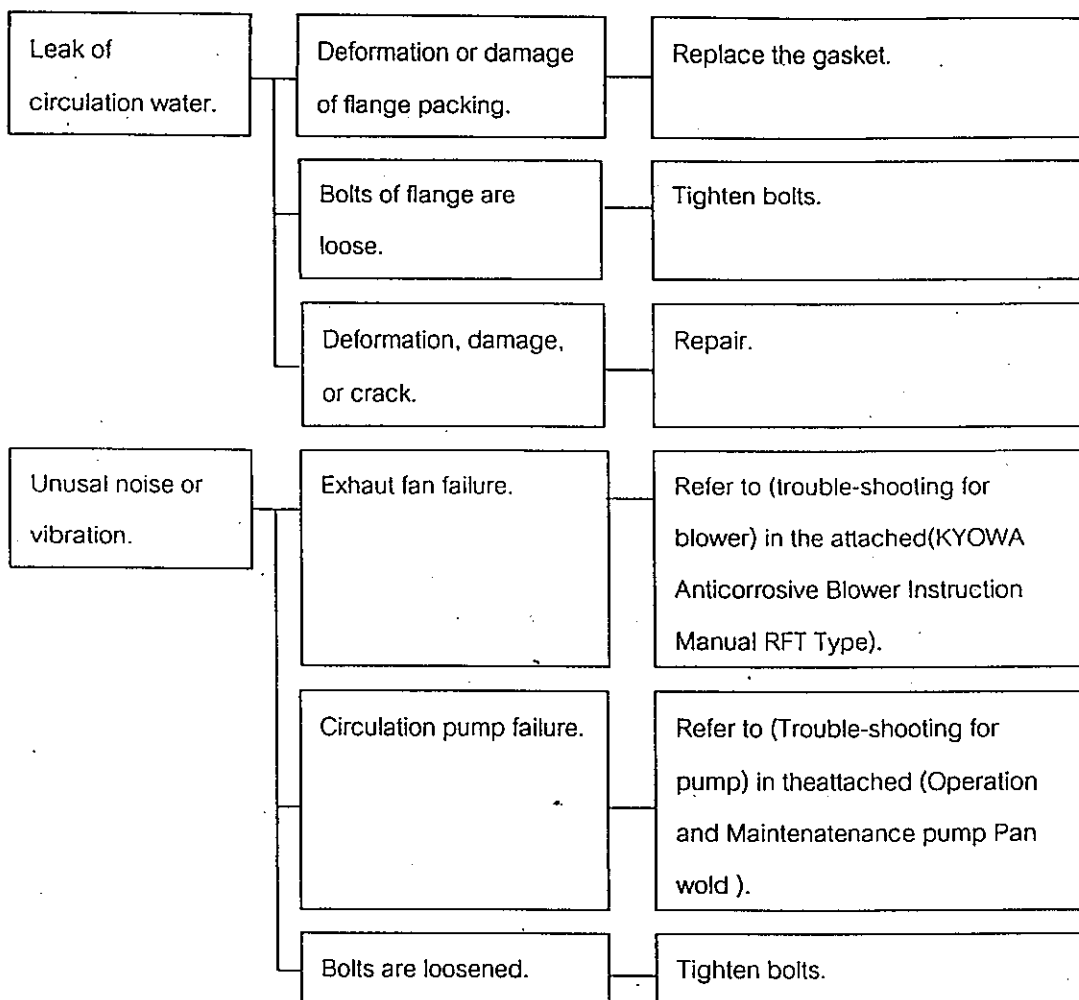

11. Guarantee

The unit is guaranteed for one year after delivery. If any trouble occurs, please contact us even if the term of the guarantee has expired.